

# PR12 Recessed Pool Light Instructions

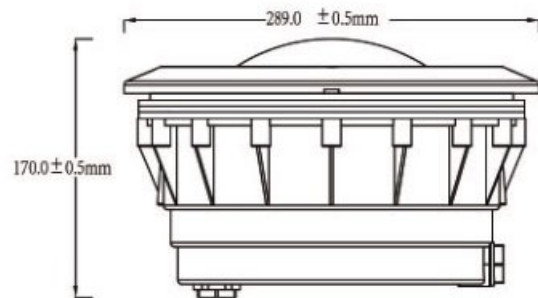

## ! CAUTIONS

1. Please read the instruction manual before installing the lamp to ensure that the power is off.
2. The instruction of this lamp must be completed by an electrician holding the relevant certificate injured by an electric shock.
3. Ensure that the electrical systems and wiring of the swimming pool facilities comply with th current national codes and local codes and regulations.

## Installation Notes

Please make sure that the Pool light form tube housing is prepared correctly before pouring concrete (Diagram A).

Pool light form tube housing must be parallel to the wall when installing

Make sure conduit is sealed properly to avoid water leakage.

Make sure junction box is above pool water level, and only use IP rated joins.

Allow 1.5 - 2metres of cable to coil up in side the form tube for any future maintenance (Diagram B)

**AT ALL TIMES NEVER TURN THE POOL LIGHT ON UNLESS IT IS SUBMERGED UNDER WATER**

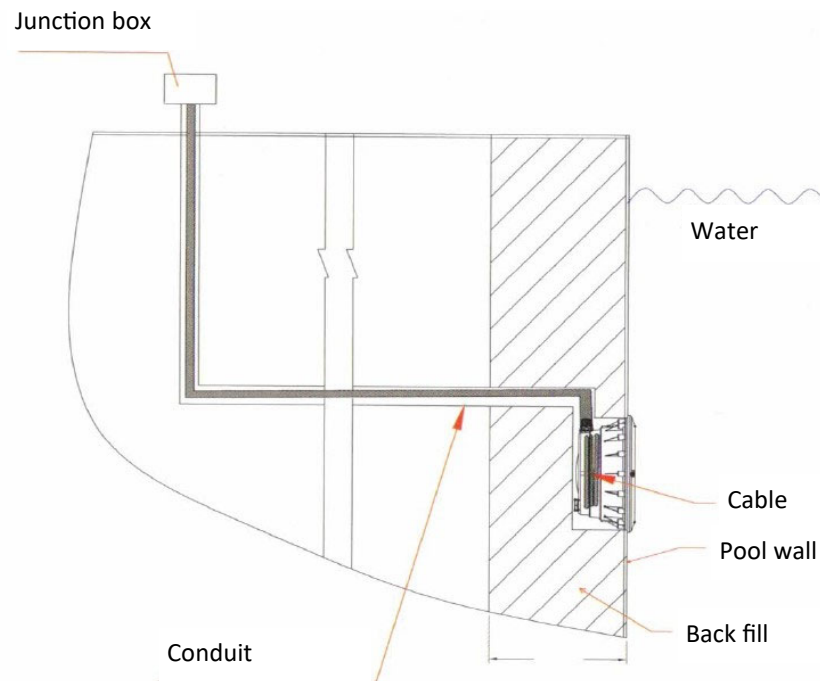

Diagram A

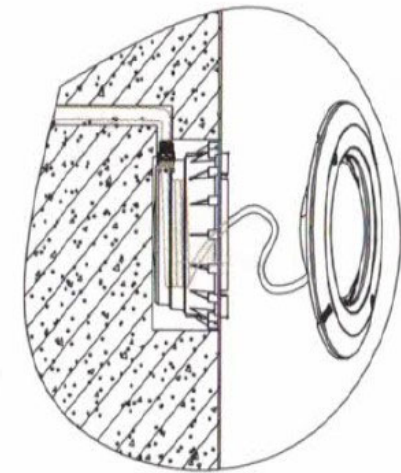

Diagram B

